

# TRIANGULARWAVE TECHNOLOGIES, INC. (TWT®)

## CHEMICAL-FREE FLUID CONDITIONING & TREATMENT for the HVAC INDUSTRY

Sensing Environmental Needs  
With Intelligent Solutions

The Difference in Technology Matters!

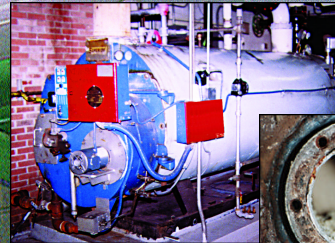
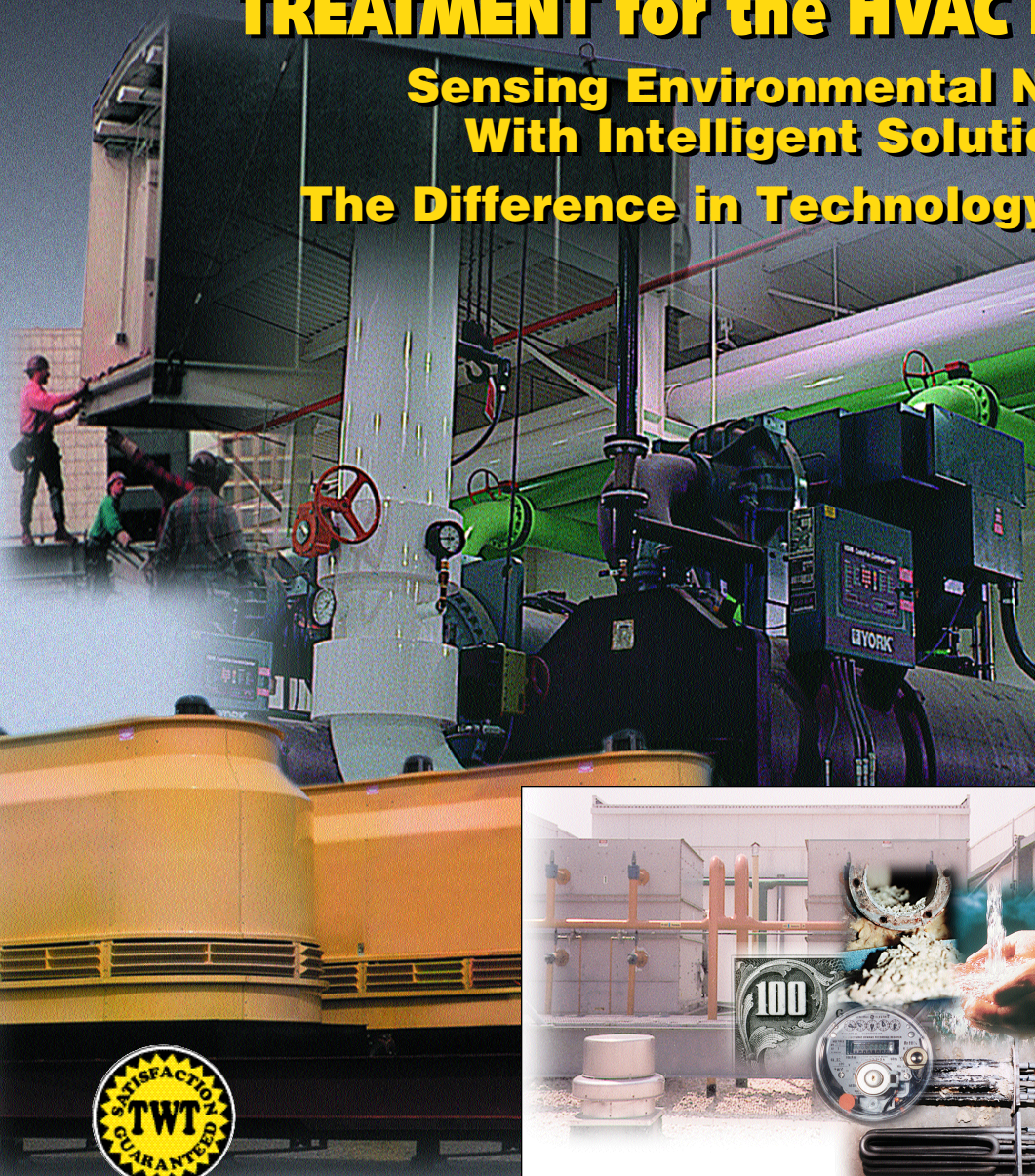

Scale Deposits

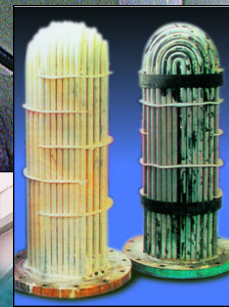

Encrusted Heat Exchangers

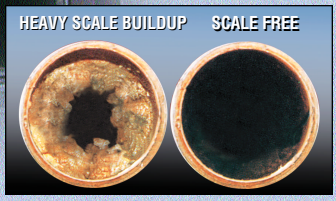

Eliminates deposits in pipes, heat exchangers and related equipment.



TWT® Saves: Chemicals, Water, Energy, Labor, Time & Materials

Triangularwave Technologies, Inc. is the Leader in Chemical-Free HVAC Fluid Conditioning & Treatment Systems. Using It's Triangularwave Deposit Control & Ionization Technology, TWT® Effectively Meets The Needs Of Any Application.

Enhancing Water Quality, Improving HVAC Operating Efficiency and Equipment Life Cycle

**GO GREEN-SAVE GREEN**

HARD WATER PROBLEMS SOLVED EASILY!

• CONSERVE WATER • SAVE ENERGY • INCREASE COOLING EFFICIENCY



# TWT Side-Stream/Bypass HVAC Industrial Water Treatment Systems. Chemical-Free Water/Fluid Conditioning and Treatment for the HVAC Industry.

(Cooling Towers, Evaporative Condensers and Chillers)



## SAVINGS:

*Hard Dollars-  
Chemicals, Water  
& Energy*

*Soft Dollars-  
Materials, Labor,  
Time & Safety*

*Lifecycle Savings-  
Typically Many  
Times the Cost of  
the TWT System*

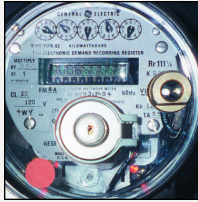

- Control and prevent scaling, corrosion and bio-fouling in heating and cooling systems.
- TWT All-In-One (custom built to suit) board mounted treatment units-deposit control technology (hard water conditioning) with ionization for re-circulating sump water application and treatment.
- The TWT Bypass Fluid Treatment System can be installed using stand-alone products and/or as a fully integrated factory-assembled & mounted treatment system, combining filtration, patented TWT Deposit Control and IonGuard purification technologies. The System is designed to provide a practical answer to large pipe diameter and recirculating fluid treatment problems. The Bypass system offers a much sought after solution at an economical price. Enhancing water quality, improving operating efficiency and equipment life cycle.

A-Using (Illustration) TWT technology as stand-alone components and/or with Ionization, In-line.

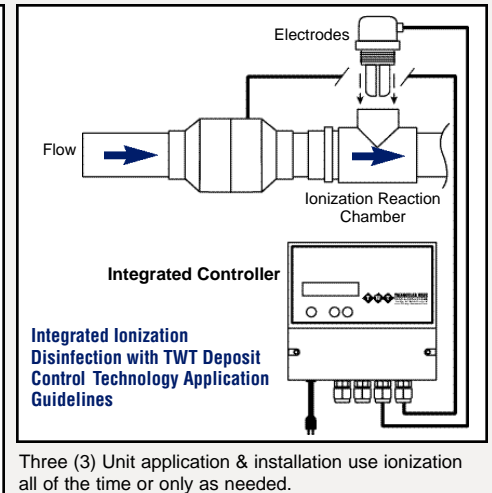
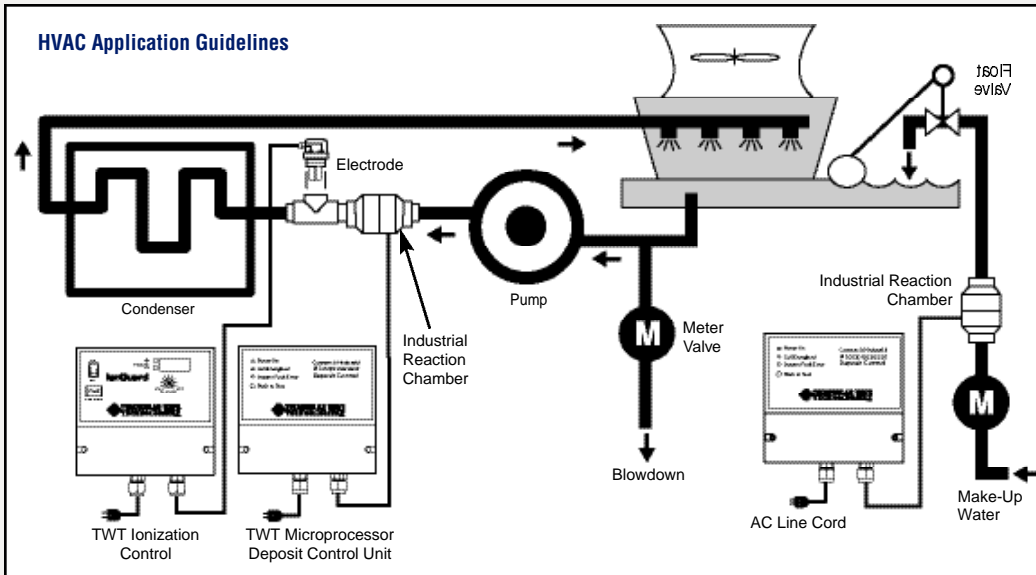

B-Using (illustration) TWT side-stream/bypass HVAC treatment unit (Use all of the time and/or only when needed).

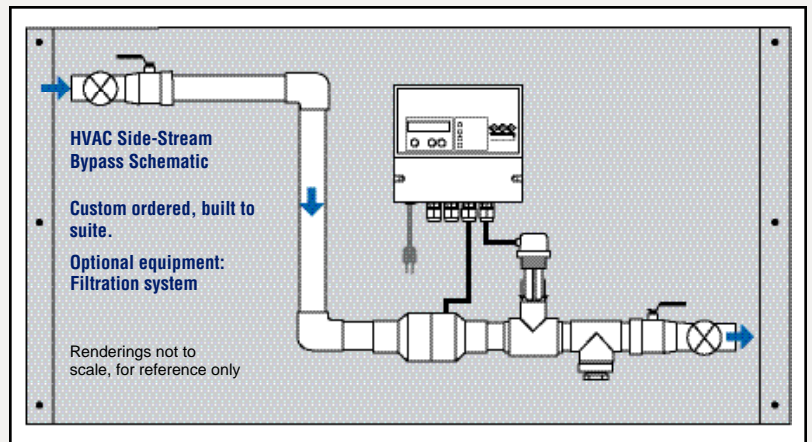
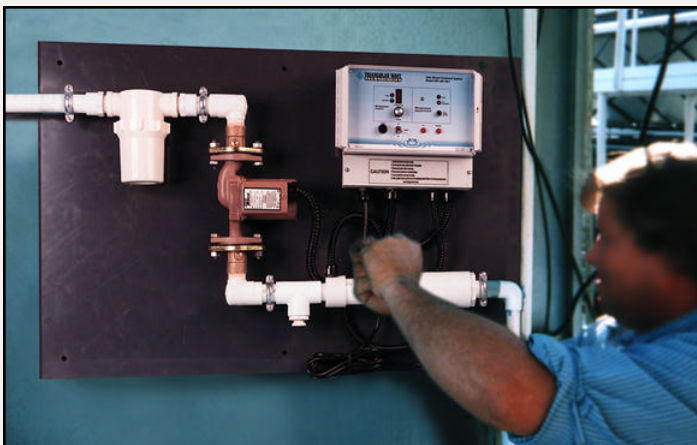

# TWT Deposit Control, Ionization, Disinfection & Purification All-In-One Board Mounted Units

## Optional Filtration Equipment: If required based on water source and quality

The first step in achieving clean water is a filtration system that effectively removes particulate matter and similar debris.

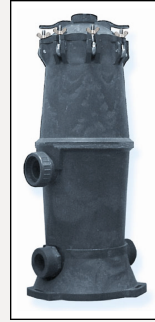
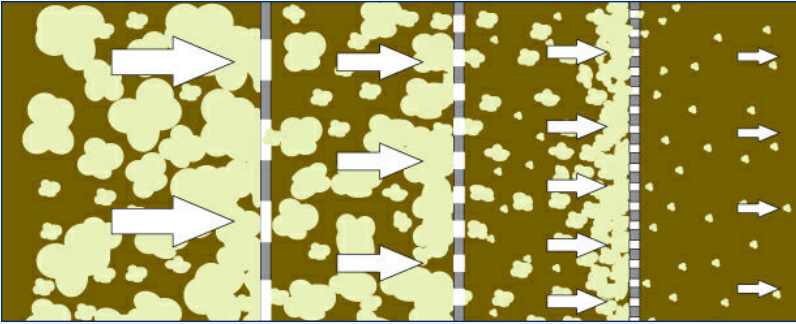

### TWT-HVACBP-1

- One (1) inch schedule 40 PVC plumbing in/out of unit.(Schedule 80 PVC available upon request.)
- Universal power supply.
- Sump water volume up to 2500 gallons of total water (using low pressure pump)
- Sump water volume up to 4000 gallons of total water (using high pressure pump)
- One (1) TWT-IRC-01 Industrial 1" Reaction Chamber
- One (1) TWT-377 0.5 Amp DC/Ionization Controller
- One (1) TWT-IDK-0265122 Electrode installation kit (3" electrodes, 2" PVC Tee, Tee Cap and Conduit)
- One (1) TWT-RE-0225 3" Replacement electrode (sent with unit)
- Manual shut off in/out of unit
- Drain port
- Fittings and other related components for its intended use
- Approximate Size 42" X 26"
- Weight:(TBD) Based on final component assembly, configuration at time of purchase.
- Optional equipment:Filtration system

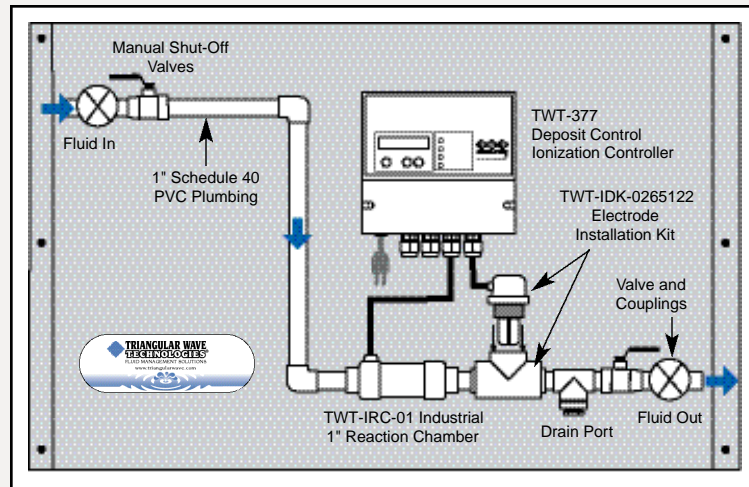

### TWT-HVACBP-2

- Two (2) inch schedule 40 PVC plumbing in/out of unit (Schedule 80 PVC available upon request.)
- Universal power supply.
- Sump water volume up to 4000 gallons of total water (using low pressure pump)
- Sump water volume up to 6000 gallons of total water (using high pressure pump)
- One (1) TWT-IRC-02 Industrial 2' Reaction Chamber
- One (1) TWT-378 1.25 Apm DC/Ionization Controller
- One (1) TWT-IDK-0265123 Electrode installation kit (6" electrodes, 3" PVC Tee, Tee cap and Conduit)
- One (1) TWT-RE-0262 6" Replacement Electrode (Sent with unit)
- Manual Shut-off in/out of unit
- Drain port
- Fittings and other related components for its intended use.
- Approximate size 52" X 28"
- Weight:(TBD) Based on final component assembly, configuration at time of purchase.
- Optional equipment:Filtration system

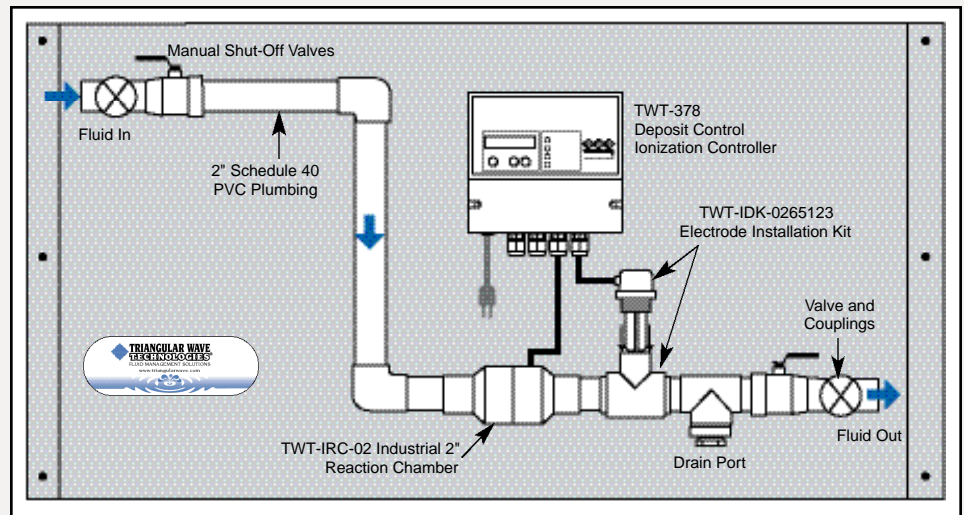

Schematic renderings not to scale, for reference only

**Quote: Custom ordered, built to suit: Quotes are meant to ensure proper use, application & Installation and based on material cost at time of purchase.**

**Larger volume (GPM) skid-mounted systems available upon request**

# TWT Deposit Control, Ionization, Disinfection & Purification All-In-One Board Mounted Units

## TWT-HVACBP-3

- Three (3) inch schedule 40 PVC Plumbing in/out of system. (Schedule 80 PVC available upon request.)
- Universal power supply.
- Sump water volume up to 6000 gallons of total water (using low pressure pump)
- Sump water volume up to 10,000 Gallons of total water (using high pressure pump)
- One (1) TWT-IRC-03 Industrial 3" PVC Reaction Chamber
- One (1) TWT-379 2-Amp DC/Ionization Controller
- One (1) TWT-IDK-0265124P 6" four prong electrodes installation kit (6" four prong electrodes, 4" PVC Tee, Tee Cap and conduit)
- One (1) TWT-Re-0264P 6" four prong replacement electrodes. (Sent with unit)
- Manual shut off in/out of unit
- Drain port
- Fittings and other related components for it's intended use
- Approximate size 52" X 28"
- Weight: (TBD) Based on final component assembly, configuration at time of purchase.
- Optional equipment: Filtration system

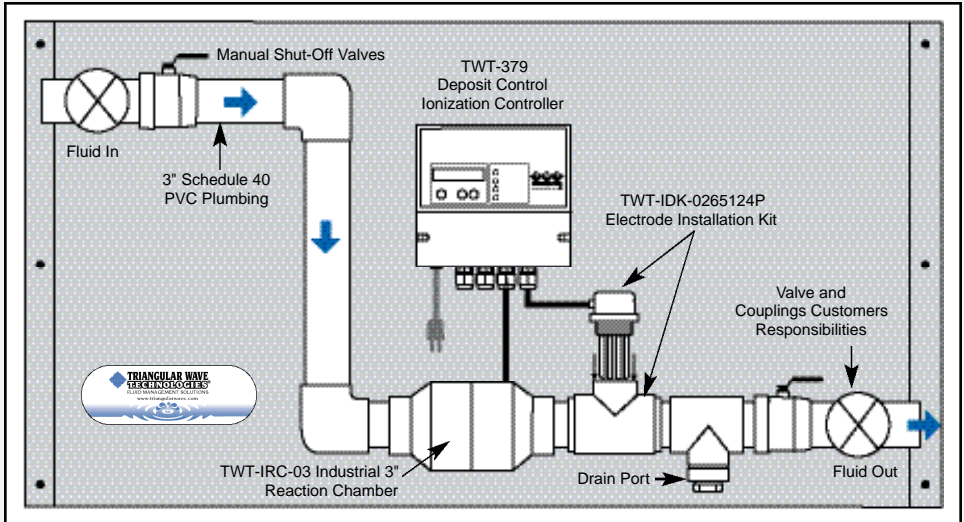

Schematic renderings not to scale, for reference only

The bypass/side stream units are provided with a ST/ST mounting board. Select a suitable location for application. Units are provided with mounting holes suitable for most job site installation. Select a location (out of harms way and protected from the environment) for the treatment system that is above the system pump selected.

### *In general, Installation of the unit should follow five steps.*

- 1- Mounting of the unit on the appropriate support structure
- 2- Installation of connecting piping (based on pipe size of supplied equipment) that will allow the redirection of water from the water (sump) system, transport the water to the bypass/side stream unit and return the water to the water (sump) system. Recirculation the water as recommended.
- 3- Connecting the bypass treatment unit to the connecting piping.
- 4- Connecting the bypass treatment unit to the remote (timer) control unit.
- 5- Connecting the bypass treatment unit to the electrical power supply.

### **Please Note:**

System engineering design, weight, size and system component assembly may vary based on TWT engineering review, water conditions, application, industry and/or customer specific needs

Pumps, piping and other related materials to and from units, customer's responsibility.

When using the TWT bypass system and if not installing TWT deposit control technology as recommended by TWT, Inc. in-line, it is suggested to install a deposit control unit on the make-up water feed line. The combined treatment approach will provide end-to-end conditioning all of the time.

TWT, Inc. provides product, system and technical support, before, during and after all sales and installations.

In Effect, a clean, corrosion-free delivery system is restored and maintained in an environmentally safe and Chemical-Free manner. The result is clean pipes, tubing and equipment with **NO** bio-film and/or bacterial contamination.

### **PROTECTION FOR NEW EQUIPMENT**

Provides new equipment with the ability to enhance it's features a benefits

### **TREATMENT FOR EXISTING EQUIPMENT**

Retrofit existing equipment to improve its operating efficiency and life cycle

*The return on investment of a TWT system is undeniably significant from operation, economical, and safety pint-of view.*

*DON'T WAIT...contact us today for information on how to purchase the system that works best for you!*

**Conserve Water, Save Energy...Non-Chemical, Safe, Cost-Effective Water Treatment Systems**

**TWT® The Ultimate in Alternative Energy, Water Treatment & Conditioning**

**Go Green - Save Green!**

